

Curved Back Adirondack Chair

Inch-thick
mahogany
will weather well
with or without
a finish



BY SCOTT MASI

My grandfather, who is almost 90 and not as spry as he used to be, pointed out to me that the comfort of a chair isn't just based on how good it feels when you sit in it but also on how easy it is to get out of. A beanbag chair is a good case in point. Sitting in one might be as comfortable as being in the womb; but getting out of one is about as difficult.

When I finished boat-building school, I sort of fell into the Adirondack-chair business by accident. The first chair was made as a wedding present. The design was adapted from an old chair my mother had bought at a yard sale. The chair was such a hit with the newlyweds that they quickly wanted a few more. Word got

around that I was making the chairs, and the next thing I knew, I was in business. I'm not sure how many Adirondack chairs I've made by now, but it has to number in the thousands. I have patterns for all of the pieces and several simple jigs for the construction. After all of the pieces are cut and sanded, it takes me about 45 minutes to put a chair together.

Mint-julep arms and a comfortable slope

There are as many different designs for Adirondack chairs as there are mosquitoes in the Adirondack Mountains. All of the old chairs had arms wide enough to rest a drink on, and most of them had a

MAHOGANY ADIRONDACK CHAIR

This comfortable chair, made of 1-in.-thick mahogany, has a curved back and a flat seat. To prevent splinters, all exposed edges are chamfered with a ¼-in. roundover bit, and all surfaces are sanded. Screw holes are plugged with epoxy-coated bungs.

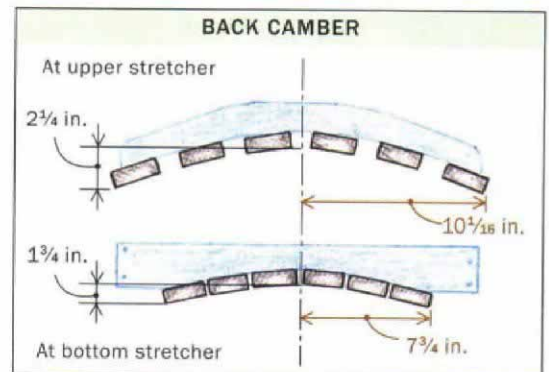
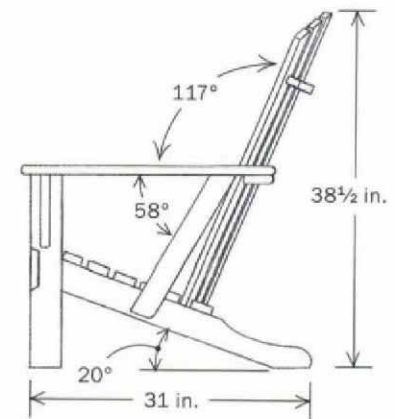
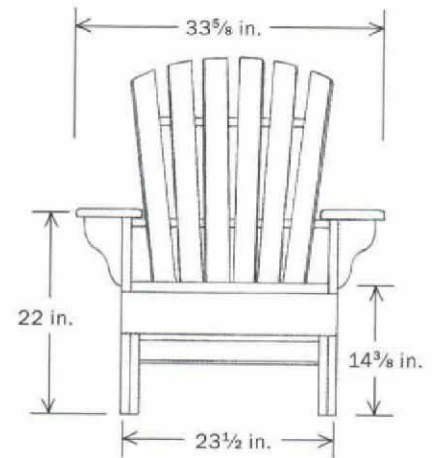
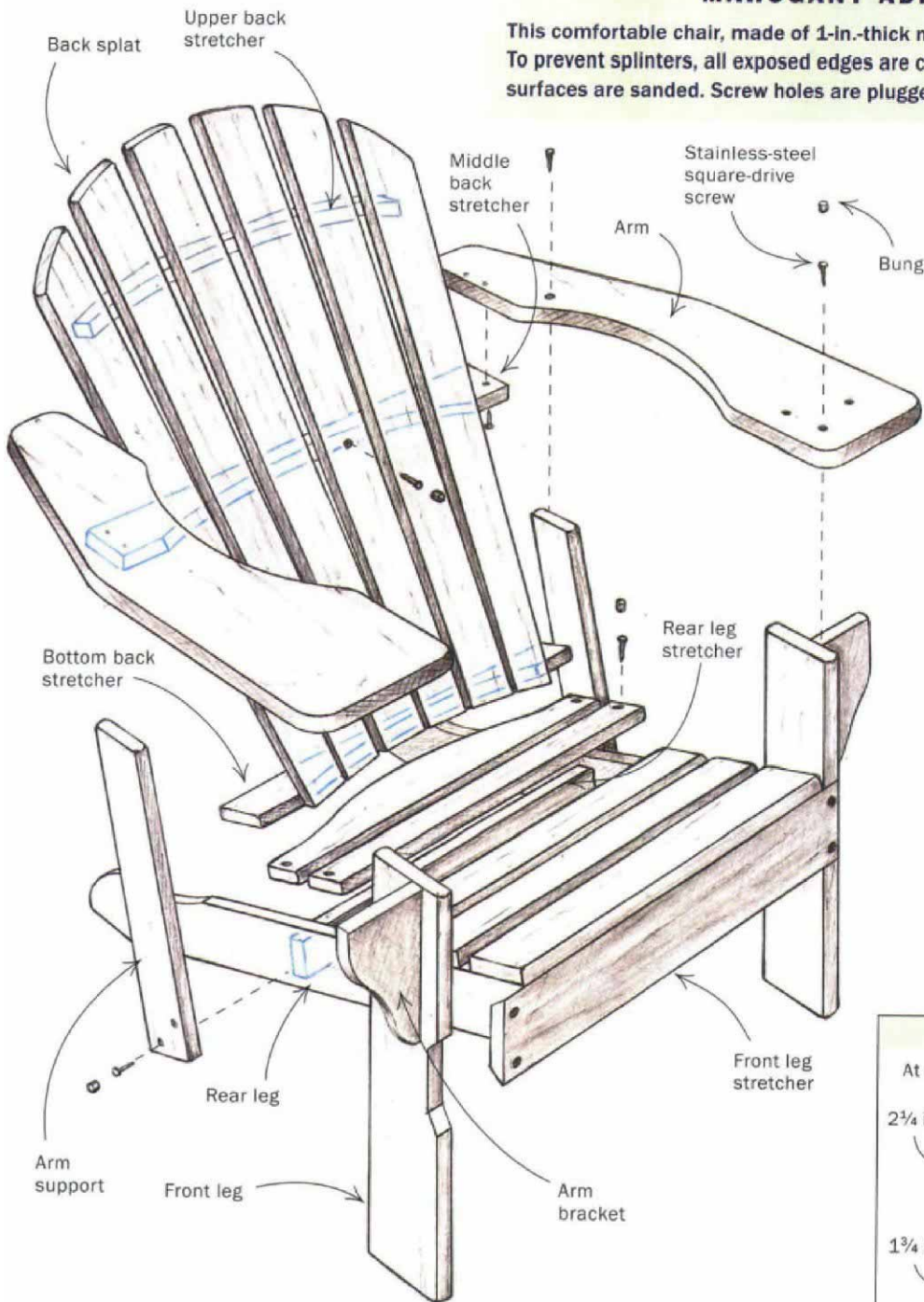

flat seat and a flat back. Many of the newer designs employ curves in the seat and the back.

An early prototype of my current chair was built with a deep curve to the seat. The chair looked graceful, but to get out of it my grandfather had to scootch way forward in the seat, grab the ends of the arms and hoist himself to his feet. In the process of hoisting, he pulled the chair's back legs off the ground, and when he stood up and let go of the chair, the legs crashed back to the ground.

It occurred to me that a flat seat would allow the sitter to be higher off the ground and thus would make getting out of the chair much easier. Besides, people are factory equipped with a padded

seat and a bony back. The chair I now make has a gentle fanned and curved back that conforms to people's unpadded backs and a flat seat that doesn't have to conform to their padded bottoms.

Trace, cut, rout, sand

It's best to trace all of the curved pieces on this chair—legs, arms, arm brackets and back stretchers—from patterns and then cut them on a bandsaw. After roughing out, screw the curved patterns to the pieces with two drywall screws and then use a pattern-routing bit on a router table. For unpainted mahogany chairs, it's important to pay attention to what side the pattern is screwed to.



Front stretcher is let into the front legs. Both long edges of the stretcher are ripped with the saw tilted 20°—the same bevel at which the rear legs meet the front legs. A simple jig (right) holds the front legs at the proper spacing.

For instance, be sure to screw the pattern to the underside of the arms so that you don't have unsightly holes in the finished surfaces. For painted chairs, where you can fill surfaces with marine putty before painting, the screw holes don't matter as much.

The importance of sanding—Imagine that you've just taken the new Stephen King novel and a tall glass of iced tea out to sit on the lawn for some summertime relaxing. You sit in your favorite Adirondack chair, and "Yeow!" you get a splinter in your factory-equipped padding. There goes the afternoon. Adirondack chairs are meant to sit outside. Whether on a covered porch or set out in the middle of a lawn, they see a lot of weather. Wetting and drying cycles can wreak havoc on wood: raising grain, raising splinters, raising the ire of those people who get the splinters.

I spend a lot of time routing a 1/4-in. radius on all exposed edges and sanding the parts of my chairs before I even put them together. And then, after they are assembled, I sand them one final time. A good deal of the chairs I make get painted. If you look around at outdoor painted surfaces, you'll notice that paint usually fails at sharp edges where the paint is thinner. The corner boards of a house are a good example. On the other hand, paint on rounded surfaces is much less likely to chip.

Trust your eyes and your fingers

I want to say a few words about my assembly methods. I don't spend a lot of time making layout lines on the Adirondack chairs I build. Granted, I've built a lot of these things, but I've always

Spaced out. Spacer blocks, attached to a longer piece of wood, are used to set distances between seat slats. The curved slat (on the bench) conforms to the curve of the chair's back.

trusted my eyes and my hands to guide me during assembly. For instance, rather than spending time measuring and finding centers, I'll simply hold a piece in place, judging with my hand as to whether the piece is centered before I drill a hole and screw it in place. I build the chair on a bench, and the flat surface ensures that the chair won't rock when it's all done.

It's amazing how accurate your hands are if you'll only trust them. You can feel whether a reveal is equal faster than you can by measuring it, and I'll bet my tactile tolerances are within 1/16 in., if not within 1/32 in. If I ever see anyone measuring my chairs with a micrometer instead of sitting in them and enjoying them, I'll chase them into the ocean with a stick.

Build the chair from the ground up

It may seem obvious, but I've found after making a thousand or so chairs that the way to put the things together is in three sections: first build the legs and seat; then the arms and supports; and then the back. Several simple spacing jigs facilitate assembly.

Legs and seat—Aside from the stretcher, which is let into the two front legs, all of the pieces of the chair are butted and screwed to each other. The front stretcher is cut on both edges at 20°—the same angle at which the rear legs meet the front legs—so that the first slat on the seat sits flush on the back legs and on the front stretcher. A block of wood cut to the distance between the inside dimension of the two front legs makes it easy to assemble the front stretcher. Coat the ends of the stretcher with marine epoxy before you screw it to the legs. The epoxy is incredibly strong, and as a general rule, I glue all major chair joints before fastening them with stainless-steel square-drive screws.

Once the stretcher is attached to the front legs, screw the back

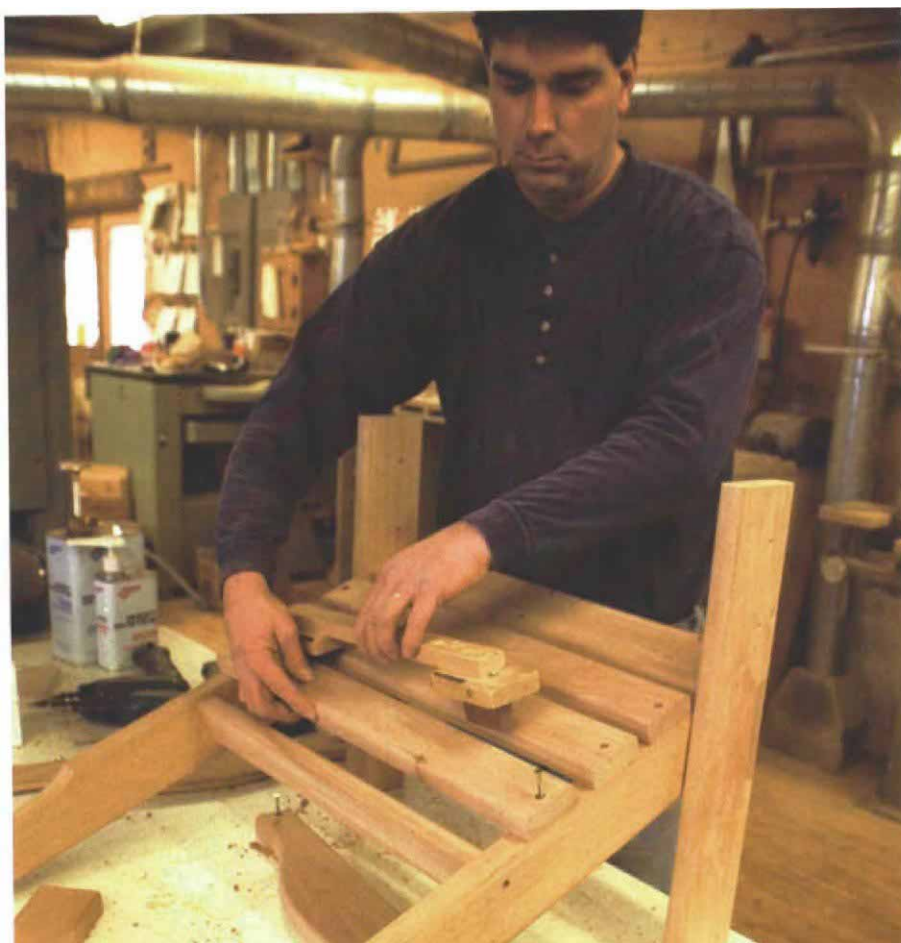



Arm supports butt into arms and rest against middle stretcher. The curved stretcher holds the arms apart at the proper distance. The chair's back splats will be screwed to the stretcher,

legs to the front ones right behind the front stretcher and then attach the rear stretcher between the back legs. The base of the chair will now stand on its own, and it's ready for the seat slats. To help achieve consistent spacing between slats, use a length of scrap with $\frac{11}{16}$ -in.-thick spacer blocks screwed to the bottom.

Arms, brackets and supports—After the legs and seat slats have been screwed together, it's time to turn to the arms and arm brackets and supports. The backs of the arms are held apart the proper distance by a piece that doubles as a middle back stretcher. The back stretcher's front edge is bandsawn at 30°.

I coat the top end grain of the front legs with epoxy before attaching the front of the arms with 2½-in. screws. Epoxy on end grain! I can hear you laughing in your beard. Contrary to what you might believe, epoxy has amazing holding power on end grain. I once had to disassemble a finished chair, and after removing the screws into the end grain, the arms still wouldn't come off the legs. I used a lot of force pushing on the backs of the arms to break the glue bond, and when it finally broke, the wood in the arms broke but not the glue joint. So much for woodworking heresy.

Once the arms and brackets have been attached, screw the arm supports in place so that they butt against the front edge of the middle back stretcher. Then turn your attention to the curved back.

Curved back—The back has to be made as a separate section and then slid into place as one piece because the screws that hold the back splats to the bottom back stretcher are inaccessible once the seat slats are in place.

I build Adirondack chairs in lots of 10 or more at a time, so I've made a plywood rack that makes it easy to align the back splats to the curved stretchers. For one chair, you don't need to go through this trouble. For the first chair I made, I screwed the back together and then traced a fair curve across the top of the back splats. When I got a curve that pleased my eye, I unscrewed the splats from the back, cut the angles on the splats and then routed the edges.



Building the back. A jig holds the bottom and upper back stretchers while the author screws on the back splats. He uses spacer blocks at the bottom and middle of the splats.

When you have the back splats screwed to the bottom and upper stretchers, you should bung the screws that attach the splats to the bottom stretcher because, as mentioned before, the screws will be inaccessible once the back is attached to the chair. The back section should slide in over the middle stretcher that also serves to hold up the backs of the arms. Drill and screw through the back splats into the middle stretcher, and aside from finishing, the chair is done.

Finish up

After a chair has been completely screwed together, mix up another batch of marine epoxy. Coat the bungs that cover the screws, then tip the chair over and paint a thick coat of epoxy on the bottom of the four legs. Even though the chair is made of mahogany—a rot-resistant wood—some extra protection on the end grain can't hurt.

After a little final sanding, the chair is finished. The chair in the photos was left unfinished, and on Maine's coast, the chair will eventually turn gray. Some customers want their mahogany chairs painted, and I make a lot of pine chairs that also get painted. I spray on two coats of primer and two coats of finish for my chairs. What I've found works best is to use latex paint on the pine chairs and alkyd paint on the mahogany ones. □



Scott Masi makes Adirondack chairs and garden furniture in York, Maine.